

Heritage  
Design

Beauty

Vermont Castings  
elegance  
Vent-Free  
convenience



Cast Iron  
Vent-Free Gas Stoves



Strength

Heart of your home

Performance

Add the beauty of a Vermont Castings gas stove, practically anywhere!

Two great looks. Two great stoves. Now, it's easy to find just the look you're looking for in a great Vent-Free Vermont Castings Stove.

**Cast Iron Vent-Free Gas Stoves**

**Radiance**

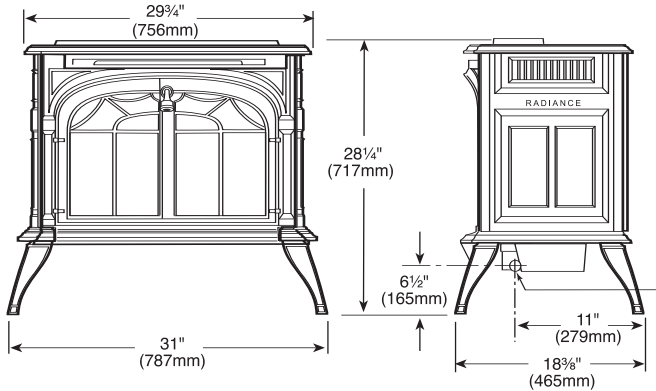

**Stardance**

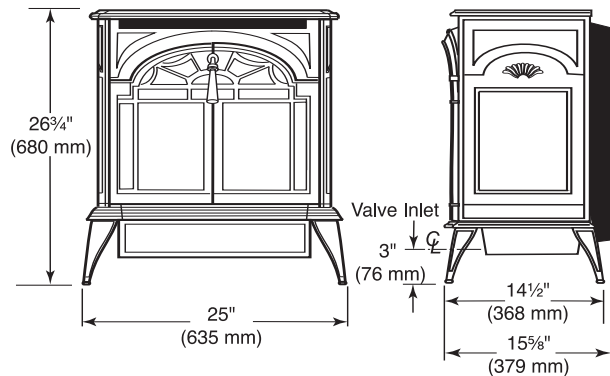

**Vent-Free Gas Stoves  
 Versatile Installation**

- Uses no venting system - similar to a gas kitchen range
- Convenient to install
- Can be installed virtually anywhere in the home - as per sizing guidelines and BTU input
- Optional PuriFLAME internal filter system allows for a cleaner burn
- Can be installed directly over combustible flooring (except for carpeting and linoleum)

Note that vent-free stoves are not sold in certain States or Provinces.

**LEGEND** → COLD AIR FOR COMBUSTION → EXHAUST → CONVECTED HEAT → RADIANT HEAT

**Features and Benefits**

- Insta-Flame ceramic burner for realism and durability
- Full adjustable heat 26,000 to 35,000 BTUs on Radiance
- 19,500 to 28,000 BTUs on Stardance
- Can be operated by wall thermostat or remote control
- High quality domestically produced cast iron
- CSA design certified
- Beautiful traditional styling
- Operable doors
- ODS system for safety assurance
- Utilizes propane or natural gas
- Optional glass and catalytic filter for maximum efficiency
- Choice of Classic Black and Porcelain Enamel colors: Bordeaux, Midnight Blue, Biscuit, Chestnut Brown, Ebony Black and Vermont Classic Green
- Four "special order" porcelain enamel colors are available for both models: Granite Gray, Sage Green, Country Cookware Gray and Brick Blue
- Optional thermostat
- Optional decorative warming shelves

YOUR DEALER

