

Heritage  
Design Beauty

The Vent Free  
warmth of  
Vermont Castings



Vent-Free  
Steel Gas Stoves



Strength Heart of your home  
Performance



The easy way to gather family and friends together.

The beauty of a Vermont Castings stove. The convenience of Vent Free operation.

It all comes together in perfect harmony with this handsome go-anywhere stove.

**Vent-Free Steel Gas Stove RFSUV34**

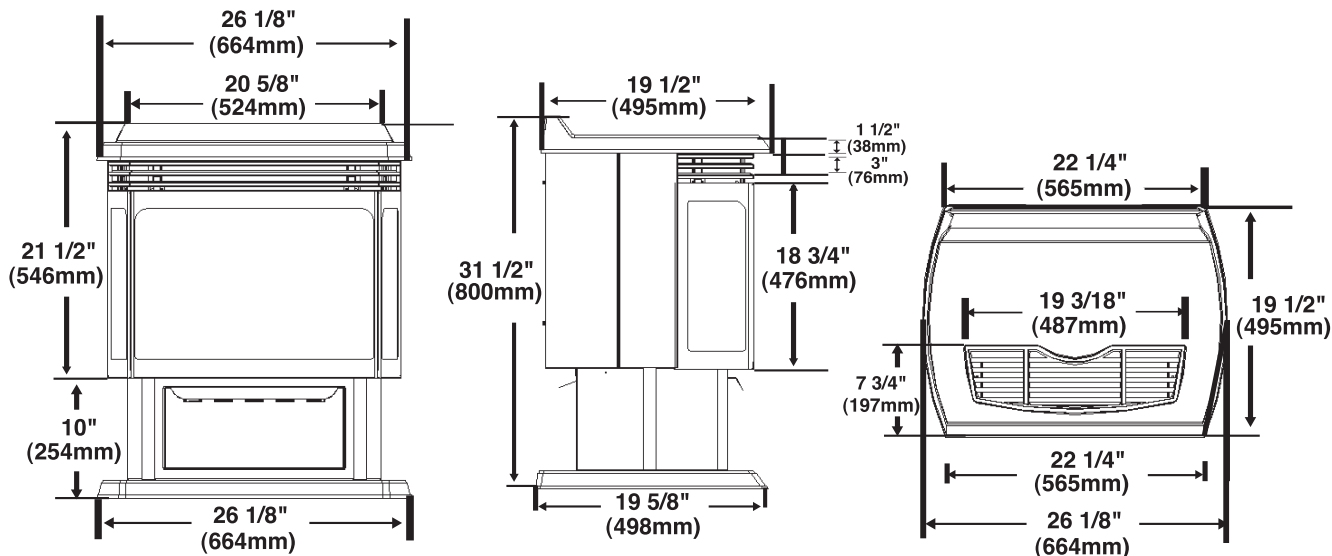

**Features and Benefits**

**Standard Features:**

- Insta-Flame ceramic burner for realism and durability
- Efficient 30,000 BTUs input natural gas and propane - modulates down to 21,000 BTUs natural gas; 22,500 BTUs propane
- CSA design certified
- Equipped with an ODS system (shut-off device) for safety assurance

**Optional Features:**

- Glass door and PuriFLAME Catalytic Filter kit for maximum efficiency
- Variable speed, heat activated fan system (FK24)
- Hand held remote
- Wall thermostat

**Vent-Free Gas Stoves - Versatile Installation:**

- Uses no venting system - similar to a gas kitchen range
- Convenient to install
- Can be installed virtually anywhere in the home - as per sizing guidelines and BTU input
- Optional PuriFLAME internal filter system allows for a cleaner burn
- Can be installed directly over combustible flooring (except for carpeting and linoleum)

Note that vent-free stoves are not sold in certain States or Provinces.



YOUR DEALER