

Selkirk, Inc. gas vent parts LISTED and produced under the Factory Inspection and Follow-Up program of Underwriters Laboratories, Inc. carry the LISTING MARK illustrated here.



CAUTION: WEAR GLOVES WHILE HANDLING METAL PARTS TO AVOID PERSONAL INJURY. SHARP EDGES OR PROJECTIONS CAN CUT YOU.



WARNING

Failure to follow these installation instructions could cause FIRE, CARBON MONOXIDE POISONING, OR DEATH. If you are unsure of installation requirements, call the Phone Number listed on the instructions or sizing handbook.

Model DF is a double wall, air cooled vent/chimney system incorporating a stainless steel inner wall, a 1/2" airspace and aluminized steel outer wall. Model DF is available in 10" through 24" diameters and is safety certified for use as a "Type B Gas Vent" (in accordance with these instructions) as well as a "Building Heating Appliance Chimney" for gas / oil fired appliance venting applications (per the Model DF chimney installation instructions). Any installation and use of Model DF as a Type B Gas Vent should be in accordance with these instructions. The following instructions reference and are also applicable to other Selkirk round Type B gas vent in sizes 3" through 8" and 26" through 48". However, such are not a part of the Model DF system.

1. GAS VENT DESIGNATIONS/JOINT METHOD

These instructions describe installation of the following sizes of Selkirk, Inc. Type B Gas Vent Pipe and associated parts.

Size	Means of Joining	Minimum Airspace Clearance
3 - 8"	Integral "Snap Lock" Coupler	1"
10 - 24"	6 sheet metal screws/joint	1"
26 - 48"	6 sheet metal screws/joint	2"

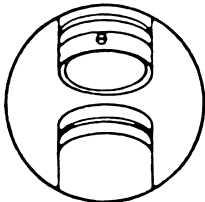

FIG. 1 3" - 8"

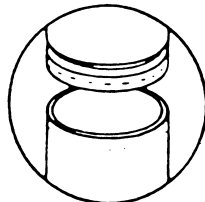

FIG. 2 10" - 48"

All joints in Selkirk, Inc. gas vents must be secured using the appropriate method. ("Snap Lock" feature for sizes 3" - 8" (Fig. 1) and sheet metal screws for sizes 10" - 48") (Fig. 2). Snap Lock by lining up the dimples of 2 lengths of Model RV and push together. Lock by twisting the pipe to stagger the dimples. Draft hood connectors must be attached to the appliance outlet with screws. Single wall connectors, if used must be secured to the appliance, to the gas vent, and at all joints with 3 sheet metal screws per joint. Attachment of vent to non-metallic outlets should be per appliance manufacturer recommendations.

NOTE: Although not required because of the integral couplers, screws are permitted to be installed at the joints in 3" through 8" vent. In such case, the screws should be located approx. 1/4" from overlapped edge and must be maximum 1/4" in length so they do not pierce or deform the inner liner.

2. TYPES OF APPLIANCES AND BUILDINGS

Type B Gas Vents are for venting of Listed (L.P. or natural) gas-burning appliances equipped with draft hoods and other Listed gas appliances specified for use with Type B gas vents. These appliances include (but are not limited to) the following types: furnaces, boilers, water heaters, room heaters, unit heaters, duct furnaces, floor furnaces, and decorative appliances.

DO NOT USE Type B Gas Vent for wall furnaces "Listed" for use with Type BW Gas Vents only, incinerators and appliances Listed for use with chimneys only, combination gas-oil burning appliances, and appliances which may be converted readily to the use of solid or liquid fuels. DO NOT USE Type B Gas Vent for Category II, III, or IV appliances, or for any gas-burning appliance which requires either a pressure-tight or liquid-tight venting system.

All sizes of Selkirk, Inc. Type B Gas Vents may be used in single and multi-story buildings. All Type B Gas Vents may be used for both individual and multiple appliance venting. Selkirk, Inc. Type B Gas Vents are to be installed and used in accordance with the "National Fuel Gas Code", NFPA 54, the "Standard for Chimneys, Fireplace and Venting Systems", NFPA 211, the "International Fuel Gas Code" and/or applicable local/regional codes. Selkirk, Inc. Type B Gas Vent is also suitable for use in existing, otherwise unused and new masonry chimneys to protect the chimney from the damaging effects of moist combustion products from the appliances listed above. NEVER USE

Model DF Round Type B Gas Vent Installation Instructions

Selkirk, Inc. Type B Gas Vent on any appliance that is not listed and approved for venting with Type B gas vent.

A NOTICE SHOULD BE POSTED near the point where the Gas Vent is connected to the appliance, with the following wording:

"Connect this Gas Vent only to gas burning appliances, as indicated in Installation Instructions. Do not connect to incinerators, or liquid or solid fuel burning appliances".

3. AIR SUPPLY

Gas appliances must have an adequate air supply for combustion, vent operation, and ventilation. (See Table below) Special provisions for bringing in outside air may be necessary in tight buildings or when appliances are in small rooms. Consult local building codes, or NFPA 54, "National Fuel Gas Code" for air supply requirements.

REQUIRED FREE AREA FOR EACH OPENING OR DUCT, SQUARE INCHES BASED ON TOTAL INPUT*			
APPLIANCE TYPES IN ROOM			
Air Supply Method	Draft Hood (NAT)	Combination (FAN + NAT)	Fan-Assisted (Fan Only)
A. All Air From Inside Building	sq. in. = $\frac{\text{Total Input}}{1000}$	$\frac{\text{Total Input}}{1000}$	$\frac{\text{Total Input}}{2000}$
B. All Air From Outdoors Through Wall Openings	sq. in. = $\frac{\text{Total Input}}{4000}$	$\frac{\text{Total Input}}{4000}$	$\frac{\text{Total Input}}{8000}$
B. All Air From Outdoors Through Ducts	sq. in. = $\frac{\text{Total Input}}{2000}$	$\frac{\text{Total Input}}{2000}$	$\frac{\text{Total Input}}{4000}$
C. All Air From Ventilated Attic	sq. in. = $\frac{\text{Total Input}}{4000}$	$\frac{\text{Total Input}}{4000}$	$\frac{\text{Total Input}}{8000}$
D. Air In From Craw Space Out To Attic	sq. in. = $\frac{\text{Total Input}}{4000}$	$\frac{\text{Total Input}}{4000}$	$\frac{\text{Total Input}}{8000}$

* Total Input - Total of all appliance nameplate input ratings.

4. VENT CONNECTOR TYPE AND SIZE

Selkirk, Inc. Gas Vent pipe meets all building code and safety standards for use as gas appliance vent connectors. (See Fig. 3). Correct selection of connector and vent size is detailed in the Selkirk Metalbestos Gas Vent and Chimney Sizing Handbook, the "National Fuel Gas Code" (NFPA54), and local/regional codes.

COMBINED VENT SYSTEM USING TYPE B PARTS STARTING WITH DRAFT HOOD CONNECTORS

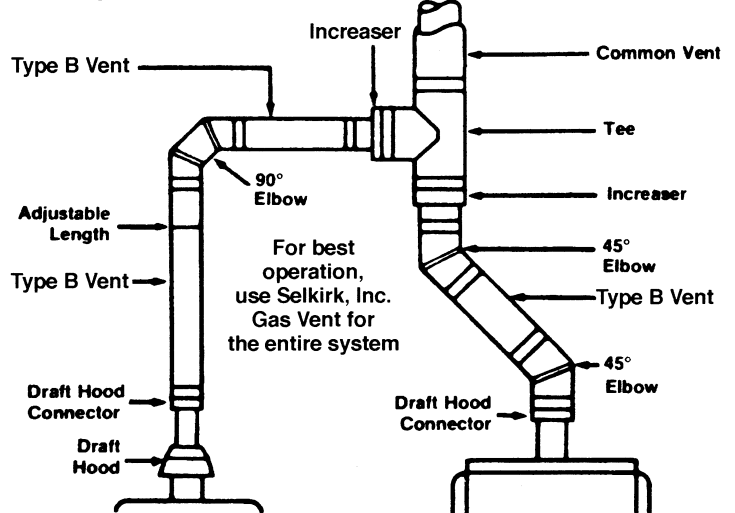

FIG. 3

5. VENT LOCATION

Selkirk, Inc. Type B Gas Vents are recommended to be installed within the heated portion of the structure whenever possible. If an exterior location is necessary it is highly recommended to enclose exposed portions (especially in cold climates) to reduce heat loss which may in turn lead to poor draft and / or condensation / icing problems. Appliances served by an exterior gas vent must have an air supply to the appliance room adequate to balance indoor and outdoor pressures. Otherwise, "stack action" of the heated building can cause reverse venting action when the appliance is off, or operating only on its pilot.

In multi-family residential, high rise and many other types of buildings, codes specify that vents must be located in fire-rated shafts or chases. (See Fig. 4) Building code requirements in such cases must be carefully followed with respect to wall construction, access, clearance, support, initial penetration of breaching, and method of termination.

6. CLEARANCES AND ENCLOSURES

Selkirk, Inc. Type B Gas Vents 3 through 24 inch sizes must be installed with **ONE INCH MINIMUM AIR SPACE CLEARANCE TO COMBUSTIBLES!** 26 through 48 inch sizes require **TWO INCHES MINIMUM AIR SPACE CLEARANCE TO COMBUSTIBLES.** These clearances are marked on all gas carrying items. They apply to indoor or outdoor vents whether they are horizontal or vertical, or pass through floors, walls, roofs or framed spaces. The appropriate clearance should be observed to joists, studs, subfloors, plywood, drywall, or plaster enclosures, insulating sheathing, rafters, roofing, and any other materials classed as combustible. **KEEP ELECTRICAL WIRES AND BUILDING INSULATION AWAY FROM GAS VENT AND OUT OF THE REQUIRED AIR SPACE!**

Single wall materials used as vent connectors are not permitted to be enclosed. There is no need to enclose Selkirk, Inc. Gas Vent where used as connectors under floors, in crawl spaces and basements, or in normally unoccupied or in inaccessible attics. Enclosing the vertical portions of vents is recommended where they pass through rooms, closets, halls or other occupied spaces.

7. FIRE STOPPING

All Type B gas vents passing through floors, ceilings or walls must be firestopped using 26 gauge or heavier galvanized steel. (See Fig. 5 and 6.) The fire stop must close the area between the outer wall of the pipe and the opening in the structure. In attics the fire stop should be placed on top of the framed opening. **KEEP WIRES AND INSULATION OUT OF REQUIRED AIR SPACE AROUND GAS VENT!**

Fire stops may be used as vent pipe supports. See Section 10. For gas vents within a shaft or chase, firestopping is provided by the vertical walls of the shaft. Any openings in the chase / shaft below the roof must be firestopped.

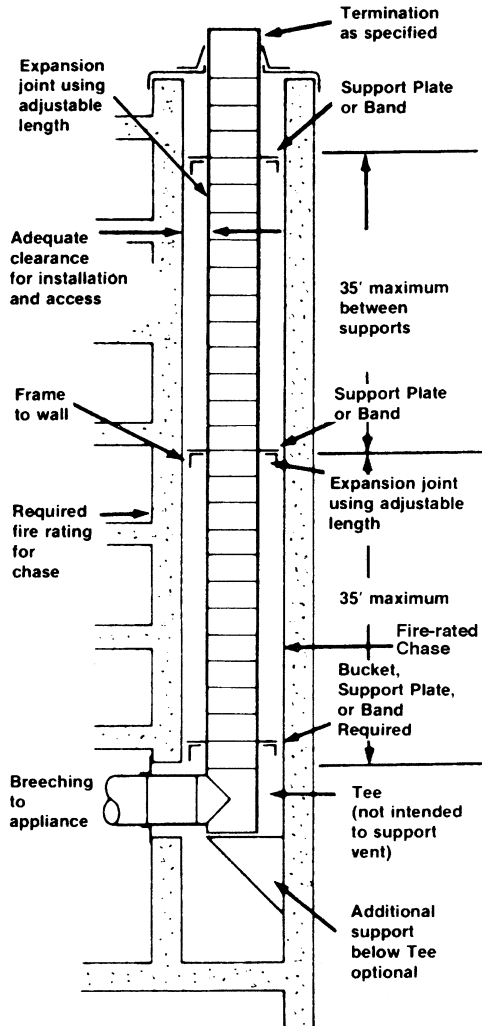

FIG. 4
CHASE INSTALLATION OF LARGE SELKIRK, INC. TYPE B GAS VENT IN MULTI-STORY BUILDING

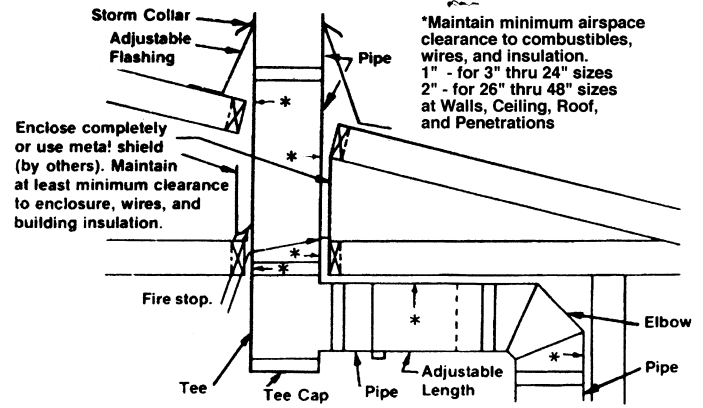

FIG. 5
TYPICAL CEILING AND ROOF PENETRATIONS

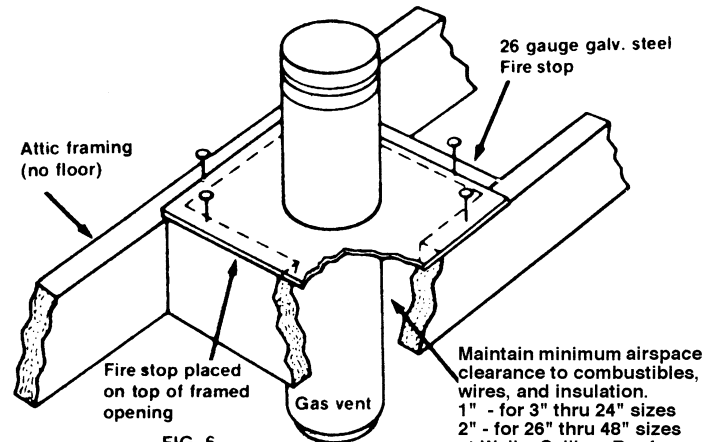

FIG. 6
FIRE STOPPING REQUIRED FOR ALL CEILING/FLOOR PENETRATIONS

8. USE OF GAS VENT FITTINGS (See Figs. 3 & 7.)

Adjustable lengths are telescoped over fixed lengths, to accommodate odd distances between vent lengths or connectors. An adjustable length suspended below a support serves as an expansion joint between two fixed points of properly supported gas vent. Ordinarily, the adjustable length must be secured, but for expansion joints it should just maintain good contact and a minimum 1-1/2" overlap. (See Fig. 10-B) **DO NOT USE adjustable lengths to suspend any weight of pipe below.** Elbows for 3" through 8" are fully adjustable. Elbows for sizes 10" through 48" are 45 degree fixed only.

Selkirk, Inc. tees, elbows, increasers, and short lengths are specially designed to facilitate interconnections.

Tees used to start vertical vents must use a tee cap to prevent air leakage. All unused openings in a gas vent must be sealed to prevent loss of effective vent action.

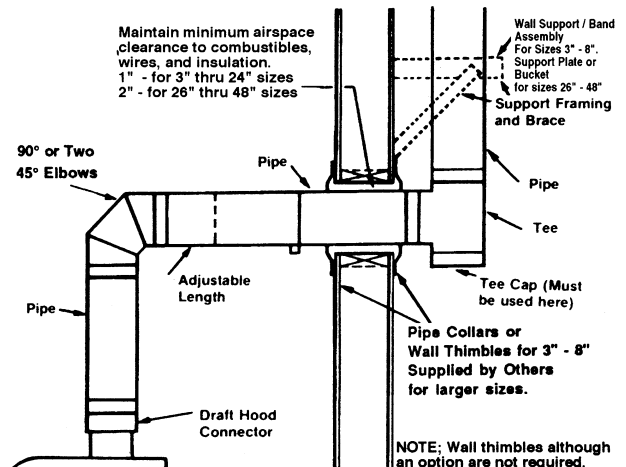

FIG. 7 - WALL PENETRATION FOR TYPE B

9. MINIMUM GAS VENT HEIGHT

A minimum gas vent height of 5 feet above the appliance draft hood is required. Where the vent has an offset, or serves multiple appliances, greater heights may be required for proper venting. Special care must be taken with short gas vents on duct furnaces, unit heaters, and furnaces in attics have sufficient vent height to assure complete venting. Refer to appliance manufacturer instructions and local codes for required minimum heights.

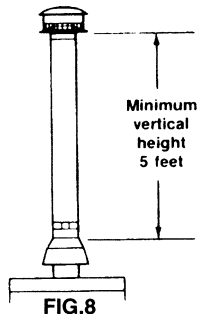

FIG. 8

10. SUPPORT

Gas vent piping must be securely supported. Lateral runs are to be supported at least every 5 feet. When offsets are necessary, adequate support above and below the offset is required. In addition, securing the offset elbow with three maximum 1/4" long sheet metal screws is recommended. Vertical runs firestopped at 8 to 10 foot intervals need only be supported near the bottom. Tees used as vent inlets may be supported by sheet metal plates or brackets. Plumbers tape may be used to support both horizontal and vertical piping. Short vents with less than 6 feet of vertical pipe below the flashing may be suspended from the flashing. (The pipe may be supported by the storm collar resting on the top of the flashing.) Use 1/4 inch long sheet metal screws to attach the storm collar to the pipe at the appropriate place. Gas vents supported only by the flashing must be guyed above or below the roof to withstand snow and wind loads. All gas vents extending above the roof more than 5 feet must be securely guyed or braced.

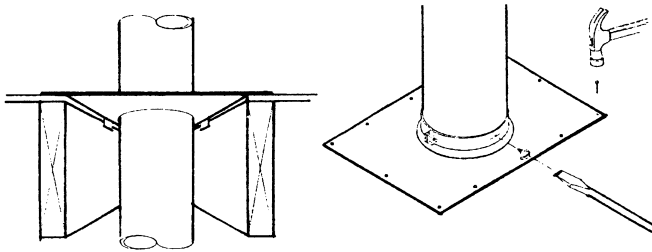

FIG. 9 FIRESTOP/SUPPORT ASSEMBLY

Indoors, gas vent sizes 3" through 8" may be supported and firestopped using the support plate. (Fig. 9). Cut away all floors and ceilings to 1" minimum air space clearance. After nailing the plate to framing, slide clamp band over pipe and pipe through hole to proper elevation. Secure band to pipe with tabs and screws so weight of pipe rests on plate. The support plate will support 35 feet of vent.

Selkirk, Inc. sizes 10"- 24" Gas Vents may be supported by using a split plate support which fits around the groove near the ends of the pipe and rests on masonry or a metal frame (See Fig. 10-A). Use bucket support for 26" and larger sizes. Suitable structural iron bands constructed from 16 gauge steel or heavier, may be used for the same purpose.

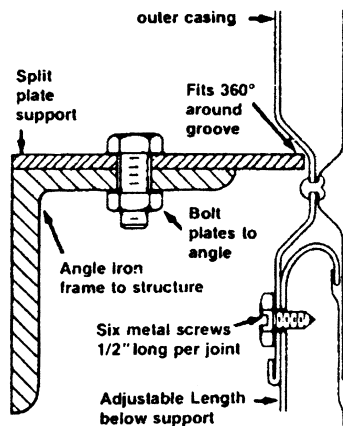
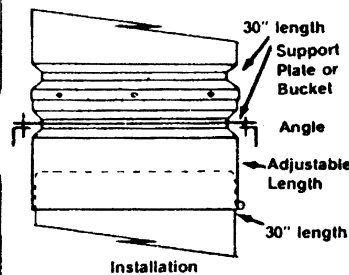

FIG. 10-A
SPLIT PLATE
SUGGESTED SUPPORT DETAIL



Note: DO NOT Use Screws in Expansion Joints or Adjustable Lengths Except at Joints to Next Pipe Section.

FIG. 10-B
TYPICAL EXPANSION JOINT
BELOW EACH SUPPORT

11. FLASHING

The roof opening should be located and sized such that the vent is vertical and has the required air space clearance. The Tall Cone Flashing is for flat roofs only (see Fig. 11-A). It is nailed in place through all four sides of the base flange. The Adjustable Roof Flashing (see Fig. 11-B) is positioned with the lower portion of the base flange over roofing material. Nail through only the upper portion and sides of the base flange. (DO NOT nail through lower flange.) Use nails with a neoprene washer, or cover the nail heads with a silicone sealant. Finish roofing around the flashing, covering the sides and upper areas of the flange with roofing material.

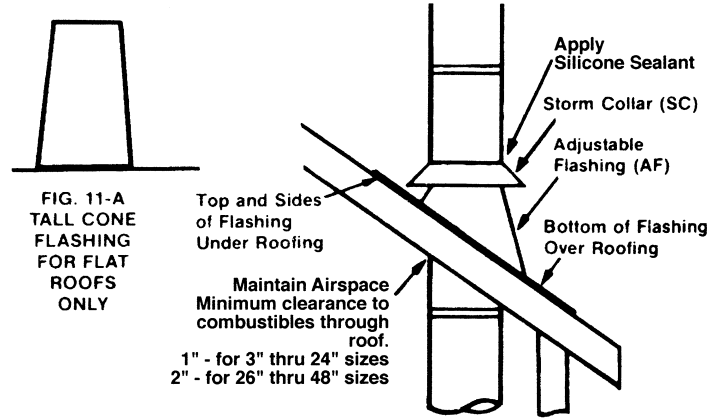

FIG. 11-B
ELEMENTS FOR PROPER ROOF FLASHING INSTALLATION

12. VENT TERMINATION

Gas vent piping must extend through the flashing to a height above the roof determined by Rule I or Rule II shown below. A storm collar is installed on the vent pipe over the opening between pipe and flashing. Silicone sealant is used over the joint between pipe and storm collar. The top is securely attached to the gas vent using the proper method for the model of pipe. (See Sections 13 and 14.)

Rule I - Tops for gas vent sizes 12" and smaller.

The cap is suitable for installation on listed gas vents terminating a sufficient distance from the roof so that no discharge opening is less than 2 feet horizontally from the roof surface, and the lowest discharge opening will be no closer than the minimum height specified in

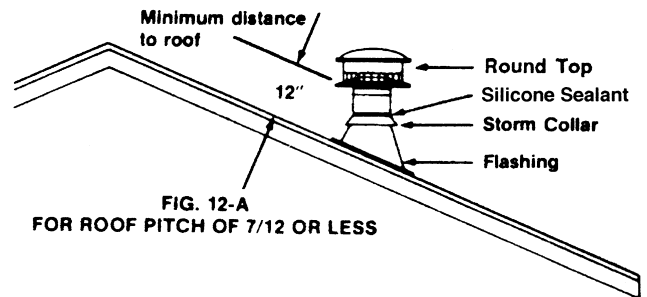

FIG. 12-A
FOR ROOF PITCH OF 7/12 OR LESS

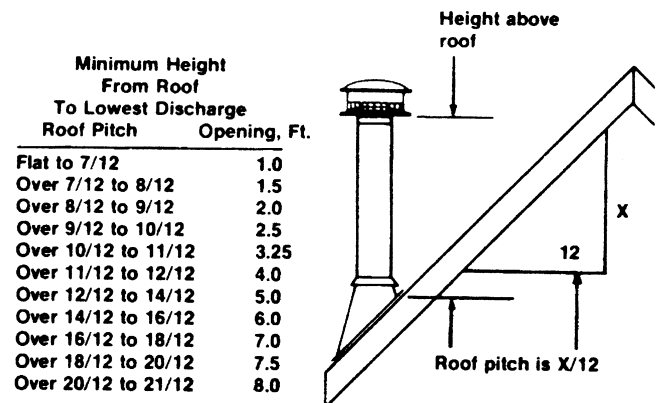

FIG. 12-B
LOCATION RULES FOR FLAT TO 21/12 PITCH

Fig. 12-B. These minimum heights may be used provided that the vent is not less than 8 feet from any vertical wall.

Rule II - Tops for gas vent sizes 14" and larger.

For installations other than covered by the table (Fig. 12-B), or closer than 8 feet to any vertical wall, the cap shall be not less than 2 feet above the highest point where the vent passes through the roof and at least 2 feet higher than any portion of a building within 10 feet. Vent caps 14" and larger must comply with Rule II regardless of roof pitch.

These rules were established on the basis of tests conducted in accordance with American National Standard ANSI/UL 441.

13. 3"-8" TOP INSTALLATION

Selkirk, Inc. Round tops (for pipe sizes 3" - 8") have a spring clip which engages and locks automatically when the top is pushed into the upper end of the pipe. (See Fig. 13-A.) The Top will also fit any single wall metal pipe having full nominal inch dimensions. (Never use single wall pipe where Type B Gas Vent is required). To attach securely, bend a one inch length of the pipe upper end inward about 1/8". The spring clip will lock under this bent edge. (See Fig. 13-B.) To remove the top from any pipe, pull up evenly on opposite sides of the skirt of the top.

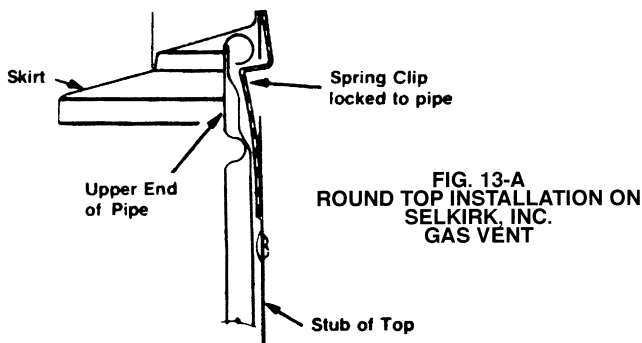
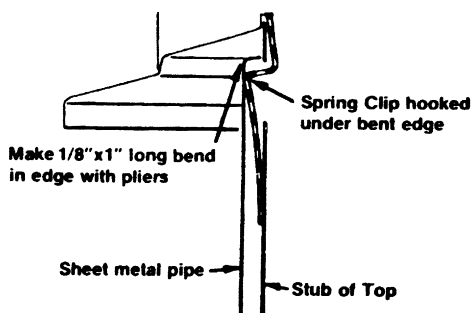

FIG. 13-A
ROUND TOP INSTALLATION ON SELKIRK, INC. GAS VENT

FIG. 13-B
ROUND TOP INSTALLATION ON SINGLE WALL PIPE



3"-8" TOP INSTALLATION

14. 10" - 24" TOP INSTALLATION

The Selkirk, Inc. Round Tops (for pipe sizes 10"-24") feature an expanding collar which clamps to the inside of the pipe and any other sheet metal pipe of similar nominal size. To install, loosen screw on top of collar and squeeze the bottom so that it will enter the pipe easily (See Fig. 14-A). Press down evenly on the skirt until it contacts the upper end of the pipe (See Fig. 14-B). Tighten the screw to expand the collar against the pipe inner (See Fig. 14-C). DON'T OVERTIGHTEN! Attempt to lift skirt to ensure top is secure.

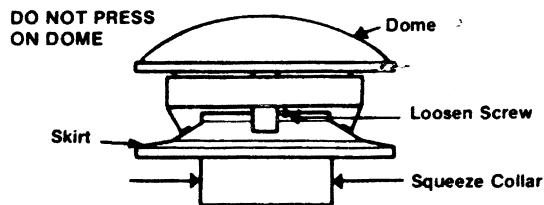

FIG. 14-A

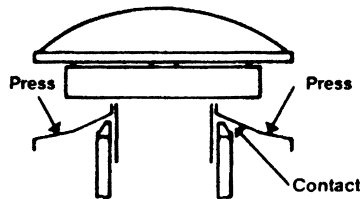

FIG. 14-B

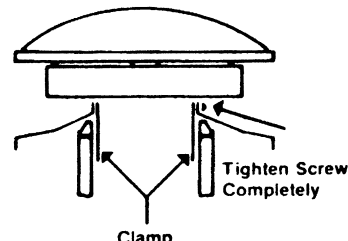

FIG. 14-C

10" - 24" TOP INSTALLATION

15. CHECKING VENT OPERATION

Complete all gas piping, electrical, and vent connections. After adjusting the appliance and lighting the main burner, allow a couple of minutes for warm-up. Hold a lighted match just under the rim of the draft hood relief opening. Proper venting will draw the flame toward or into the draft hood. Improper venting, indicated by escape or spillage of burned gas, will cause match to flicker or go out. Smoke from a cigarette will also be pulled into the draft hood if the vent is drawing properly and flow away if not.

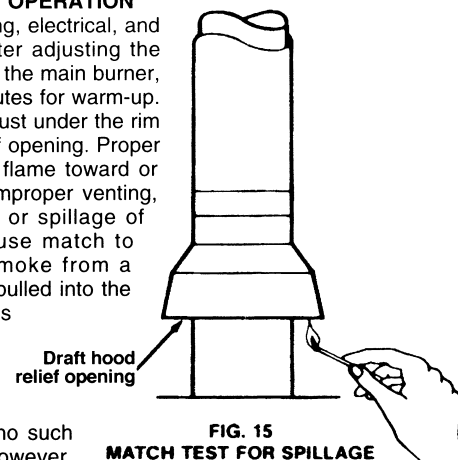

FIG. 15
MATCH TEST FOR SPILLAGE

For fan assisted appliances, which have no draft hood, no such check is available. However, Fan Assisted appliances are designed to shut down if excessive pressure is detected at the outlet. If this occurs it may be an indication that the system is not venting properly.

16. PAINTING

To prolong the life and appearance of the galvanized steel outer casing and other parts of Selkirk, Inc. Gas Vents located outdoors, use proper painting procedure at time of installation. Remove oil and dirt with a solvent. Paint first with a good quality zinc primer or other primer recommended for use on galvanized steel. Next apply an appropriate finish coat. Ordinary house paints applied directly to galvanized steel may not adhere well and do not prevent underfilm corrosion which leads to paint loosening and peeling.

These instructions should be observed when installing Selkirk, Inc. Gas Vents. Engineering methods for design and sizing of all Selkirk, Inc. Gas Vents are provided in the "Selkirk Metalbestos Gas Vent and Chimney Sizing Handbook". Following these methods will assure safe and complete removal of combustion products. For installation of Selkirk, Inc. Oval Gas Vents, see separate instruction sheet.

